



DATA DISPLAY GROUP

---

# Datasheet

## CHI MEI

### G150X1-L01

CH-01-003

Version 2.0

The information contained in this document has been carefully researched and is, to the best of our knowledge, accurate. However, we assume no liability for any product failures or damages, immediate or consequential, resulting from the use of the information provided herein. Our products are not intended for use in systems in which failures of product could result in personal injury. All trademarks mentioned herein are property of their respective owners. All specifications are subject to change without notice.

---



- CONTENTS -

REVISION HISTORY	-----	3
1. GENERAL DESCRIPTION	-----	4
1.1 OVERVIEW		
1.2 FEATURES		
1.3 APPLICATION		
1.4 GENERAL SPECIFICATIONS		
1.5 MECHANICAL SPECIFICATIONS		
2. ABSOLUTE MAXIMUM RATINGS	-----	6
2.1 ABSOLUTE RATINGS OF ENVIRONMENT		
2.2 ELECTRICAL ABSOLUTE RATINGS		
2.2.1 TFT LCD MODULE		
2.2.2 BACKLIGHT UNIT		
3. ELECTRICAL CHARACTERISTICS	-----	7
3.1 TFT LCD MODULE		
3.2 BACKLIGHT UNIT		
4. BLOCK DIAGRAM	-----	11
4.1 TFT LCD MODULE		
4.2 BACKLIGHT UNIT		
5. INPUT TERMINAL PIN ASSIGNMENT	-----	12
5.1 TFT LCD MODULE		
5.2 BACKLIGHT UNIT		
5.3 COLOR DATA INPUT ASSIGNMENT		
6. INTERFACE TIMING	-----	14
6.1 INPUT SIGNAL TIMING SPECIFICATIONS		
6.2 POWER ON/OFF SEQUENCE		
7. OPTICAL CHARACTERISTICS	-----	17
7.1 TEST CONDITIONS		
7.2 OPTICAL SPECIFICATIONS		
8. RELIABILITY TEST CRITERIA	-----	21
9. PRECAUTIONS	-----	22
9.1 HANDLING PRECAUTIONS		
9.2 STORAGE PRECAUTIONS		
9.3 OPERATION PRECAUTIONS		
10. PACKAGING	-----	24
10.1 PACKING SPECIFICATIONS		
10.2 PACKING METHOD		
11. DEFINITION OF LABELS	-----	26
12. MODULE DRAWING	-----	27

**REVISION HISTORY**

Version	Date	Section	Description
Ver. 2.0	May 23,' 06	All	Approval Specification was first issued.
Ver. 2.1	Jun 22,'06	1.2 2.1 2.2.2	Add RoHS compliance Add Note(6) Lamp maximum current 8.5mA
Ver. 2.2	Feb 8,'07	2.1	Modify data format / Delete RH-T diagram
Ver. 2.3	Aug 26,'08	3.2 7.2 7.2 9.1	Modify Backlight Unit Note(5) statement. Modify cross talk& viewing angle condition BM-5A to USB2000. Modify Optical Specification measurement setup figure. Add precaution of "Image sticking" in section 9.1 Assembly and handling precautions: (12) Do not keep same pattern in a long period of time. It may cause image sticking on LCD.
Ver. 2.4	Oct 22, '10	3.2 8	Add cautionary statement to Note(5) about life time vs. operating conditions. Split reliability test criteria from 2.1 to Chapter 8.

## 1. GENERAL DESCRIPTION

### 1.1 OVERVIEW

G150X1-L01 is a 15.0" TFT Liquid Crystal Display module with 2 CCFL Backlight units and 20 pins LVDS interface. This module supports 1024 x 768 XGA mode and can display 16.2M colors.

The PSWG is to establish a set of displays with standard mechanical dimensions and select electrical interface requirements for an industry standard 15.0" XGA LCD panel and the inverter module for Backlight is not built in.

### 1.2 FEATURES

- XGA (1024 x 768 pixels) resolution
- DE (Data Enable) only mode
- LVDS Interface with 1pixel/clock
- PSWG (Panel Standardization Working Group)
- Wide operating temperature.
- RoHS compliance

### 1.3 APPLICATION

- TFT LCD Monitor
- TFT LCD TV
- Factory Application
- Amusement
- Vehicle

### 1.4 GENERAL SPECIFICATIONS

Item	Specification	Unit	Note
Active Area	304.128 (H) x 228.096(V) (15.0" diagonal)	mm	(1)
Bezel Opening Area	307.4(H) x 231.3(V)	mm	
Driver Element	a-Si TFT active matrix	-	-
Pixel Number	1024 x R.G.B x 768	pixel	-
Pixel Pitch	0.297(H) x 0.297(W)	mm	-
Pixel Arrangement	RGB vertical Stripe	-	-
Display Colors	16,194,277	color	-
Display Mode	Normally White	-	-
Surface Treatment	Hard Coating (3H), Anti-Glare ( Haze 25)	-	-

1.5 MECHANICAL SPECIFICATIONS

Item	Min.	Typ.	Max.	Unit	Note	
Module Size	Horizontal(H)	326.0	326.5	327.0	mm	(1)
	Vertical(V)	253.0	253.5	254.0	mm	
	Depth(D)	-	-	14.35	mm	(1)(2)
Weight	-	-	1100	g	-	

Note (1) Please refer to the attached drawings for more information of front and back outline dimensions.

Note (2) The depth is without connector.

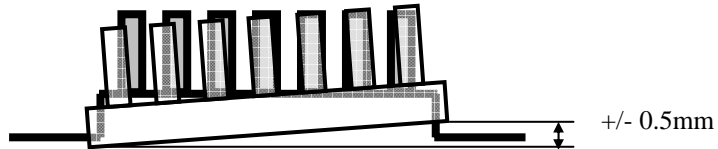

## 2. ABSOLUTE MAXIMUM RATINGS

### 2.1 ABSOLUTE RATINGS OF ENVIRONMENT

Item	Symbol	Value		Unit	Note
		Min.	Max.		
Storage Temperature	T <sub>ST</sub>	-40	80	°C	(1)
Operating Ambient Temperature	T <sub>OP</sub>	-30	70	°C	(1)

Note (1) No display malfunctions.

## 2.2 ELECTRICAL ABSOLUTE RATINGS

### 2.2.1 TFT LCD MODULE

Item	Symbol	Value		Unit	Note
		Min.	Max.		
Power Supply Voltage	V <sub>DD</sub>	-0.3	4.0	V	

### 2.2.2 BACKLIGHT UNIT

Item	Symbol	Value		Unit	Note
		Min.	Max.		
Lamp Voltage	V <sub>L</sub>	-	2.5K	V <sub>RMS</sub>	(1), (2), I <sub>L</sub> = 8 mA
Lamp Current	I <sub>L</sub>	-	8.5	mA <sub>RMS</sub>	(1), (2)
Lamp Frequency	F <sub>L</sub>	40	80	KHZ	

Note (1) Permanent damage to the device may occur if maximum values are exceeded. Function operation should be restricted to the conditions described under Normal Operating Conditions.

Note (2) Specified values are for lamp (Refer to Section 3.2 for further information).

3. ELECTRICAL CHARACTERISTICS

3.1 TFT LCD MODULE<sup>(1)</sup>

Parameter	Symbol	Value			Unit	Note
		Min.	Typ.	Max.		
Power Supply Voltage	$V_{DD}$	3.0	3.3	3.6	V	-
Ripple Voltage	$V_{RP}$	-	-	100	mVp-p	
Rush Current	$I_{RUSH}$	-	-	2.0	A	(2)
Power Supply Current	White	-	500		mA	(3)a
	Black	-	750		mA	(3)b
Differential Input Voltage for LVDS Receiver Threshold	"H" Level	-	-	100	mV	-
	"L" Level	-100	-	-	mV	-
Terminating Resistor	$R_T$		100	-	Ohm	-

Note (1) The module should be always operated within above ranges.

Note (2) Measurement Conditions:

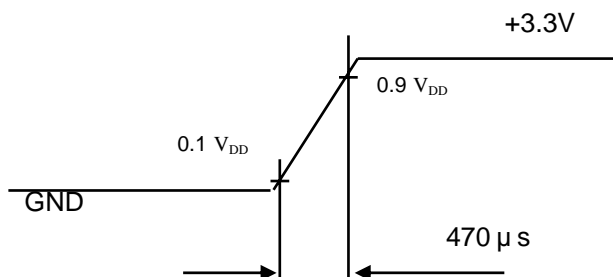
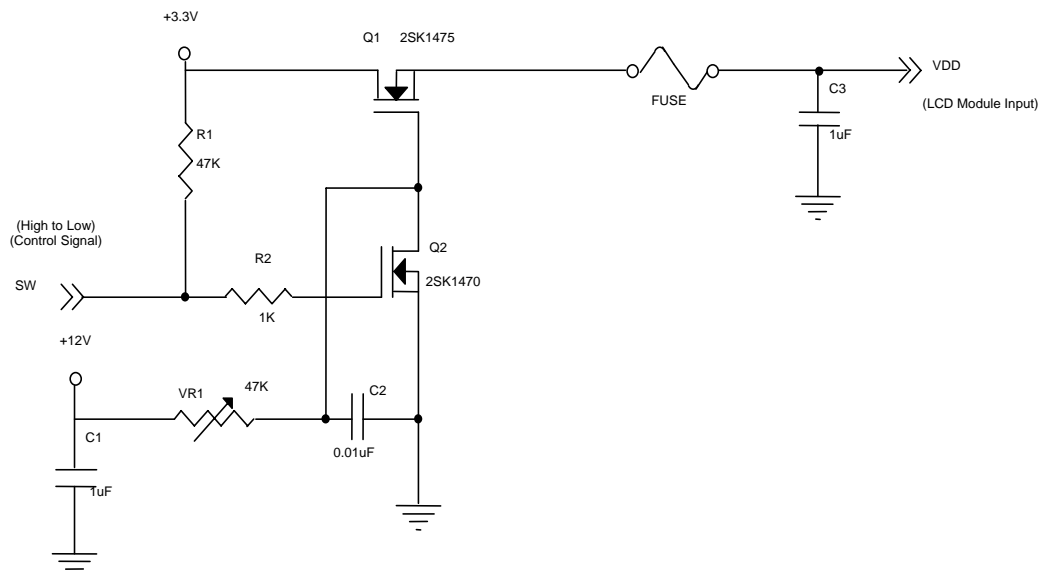



Note (3) The specified power supply current is under the conditions at  $V_{DD} = 3.3V$ ,  $T_a = 25 \pm 2 \text{ }^\circ\text{C}$ , DC Current and  $f_v = 60 \text{ Hz}$ , whereas a power dissipation check pattern below is displayed.

a. White Pattern



Active Area

b. Black Pattern



Active Area

3.2 BACKLIGHT UNIT

Ta = 25 ± 2 °C

Parameter	Symbol	Value			Unit	Note
		Min.	Typ.	Max.		
Lamp Input Voltage	V <sub>L</sub>	522	580	638	V <sub>RMS</sub>	I <sub>L</sub> = 8.0 mA
Lamp Current	I <sub>L</sub>	2	8	8.5	mA <sub>RMS</sub>	(1)
Lamp Turn On Voltage	V <sub>S</sub>	--	--	1400 ( 0 )	V <sub>RMS</sub>	(2)
		--	--	1210 (25 )	V <sub>RMS</sub>	(2)
Operating Frequency	F <sub>L</sub>	40	--	80	KHz	(3)
Lamp Life Time	L <sub>BL</sub>	50000	--	--	Hrs	(5)
Power Consumption	P <sub>L</sub>	4.18	4.64	5.1	W	(4), I <sub>L</sub> = 8.0 mA

Note (1) Lamp current is measured by utilizing a high frequency current meter as shown below:

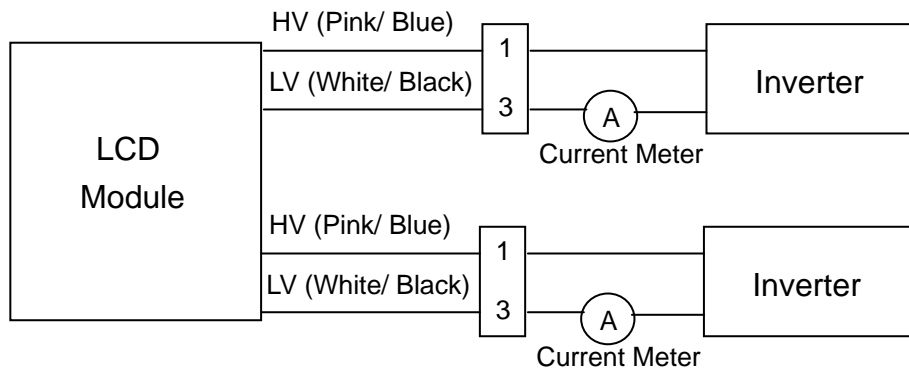

Note (2) The voltage that must be larger than V<sub>S</sub> should be applied to the lamp for more than 1 second after startup. Otherwise, the lamp may not be turned on normally.

Note (3) The lamp frequency may generate interference with horizontal synchronous frequency from the display, and this may cause line flow on the display. In order to avoid interference, the lamp frequency should be detached from the horizontal synchronous frequency and its harmonics as far as possible.

Note (4) P<sub>L</sub> = I<sub>L</sub> X V<sub>L</sub>

Note (5) The lifetime of lamp can be defined as the time in which it continues to operate under the conditions at Ta = 25 ± 2 °C and I<sub>L</sub> = 8.0mA<sub>RMS</sub> until one of the following events occurs:

- (a) When the brightness becomes ≤ 50% of its original value.
- (b) When the effective ignition length becomes ≤ 80% of its original value. (The effective ignition length is a scope that luminance is over 70% of that at the center point.)

Both life time and brightness are reduced if the lamp is operated under low temperature environment. The life time of a lamp would also shorten when operated in portrait position or cannot warm up adequately, e.g. turned ON/OFF frequently.

Note (6) The waveform of the voltage output of inverter must be area-symmetric and the design of the inverter must have specifications for the modularized lamp. The performance of the Backlight, such as lifetime or brightness, is greatly influenced by the characteristics of the DC-AC inverter for the lamp. All the parameters of an inverter should be carefully designed to avoid generating too much current leakage from high voltage output of the inverter. When designing or ordering the inverter please make sure that a poor lighting caused by the mismatch of the Backlight and the

inverter (miss-lighting, flicker, etc.) never occurs. If the above situation is confirmed, the module should be operated in the same manners when it is installed in your instrument.

The output of the inverter must have symmetrical (negative and positive) voltage waveform and symmetrical current waveform. (Unsymmetrical ratio is less than 10%) Please do not use the inverter which has unsymmetrical voltage and unsymmetrical current and spike wave. Lamp frequency may produce interface with horizontal synchronous frequency and as a result this may cause beat on the display. Therefore lamp frequency shall be as away possible from the horizontal synchronous frequency and from its harmonics in order to prevent interference.

Requirements for a system inverter design, which is intended to have a better display performance, a better power efficiency and a more reliable lamp. It shall help increase the lamp lifetime and reduce its leakage current.

- a. The asymmetry rate of the inverter waveform should be 10% below;
- b. The distortion rate of the waveform should be within  $2 \pm 10\%$ ;
- c. The ideal sine wave form shall be symmetric in positive and negative polarities

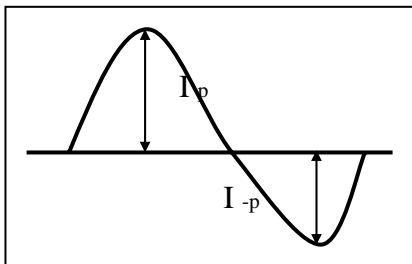

\* Asymmetry rate:

$$| I_p - I_{-p} | / I_{rms} * 100\%$$

\* Distortion rate

$$I_p \text{ (or } I_{-p}) / I_{rms}$$

4. BLOCK DIAGRAM

4.1 TFT LCD MODULE

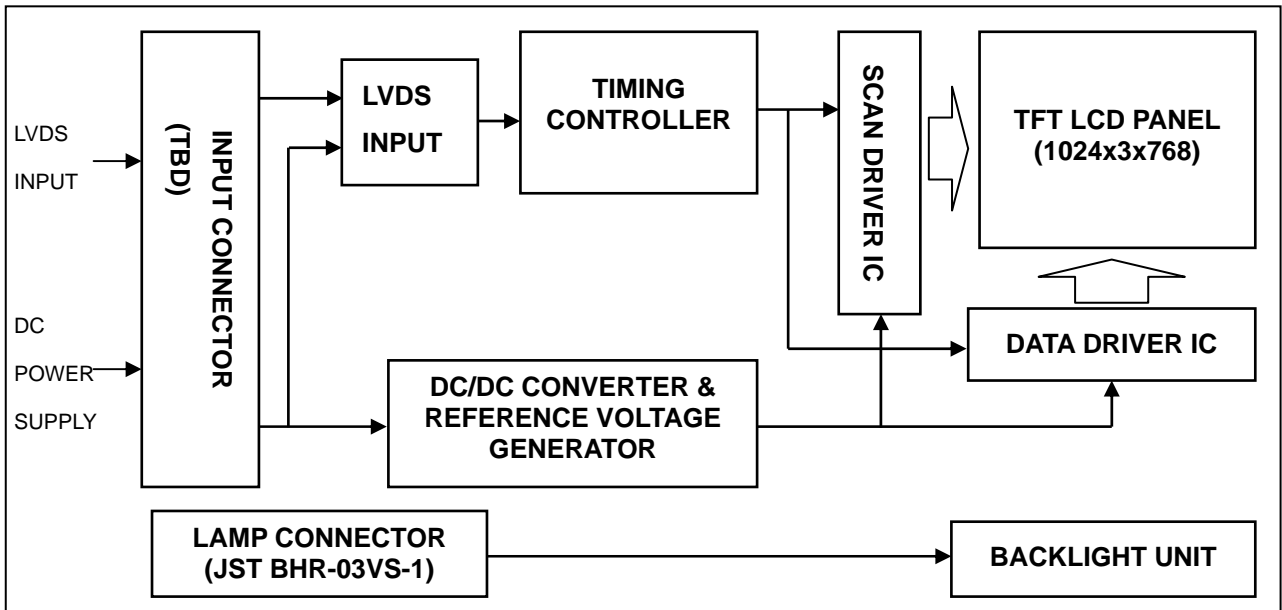

4.2 BACKLIGHT UNIT

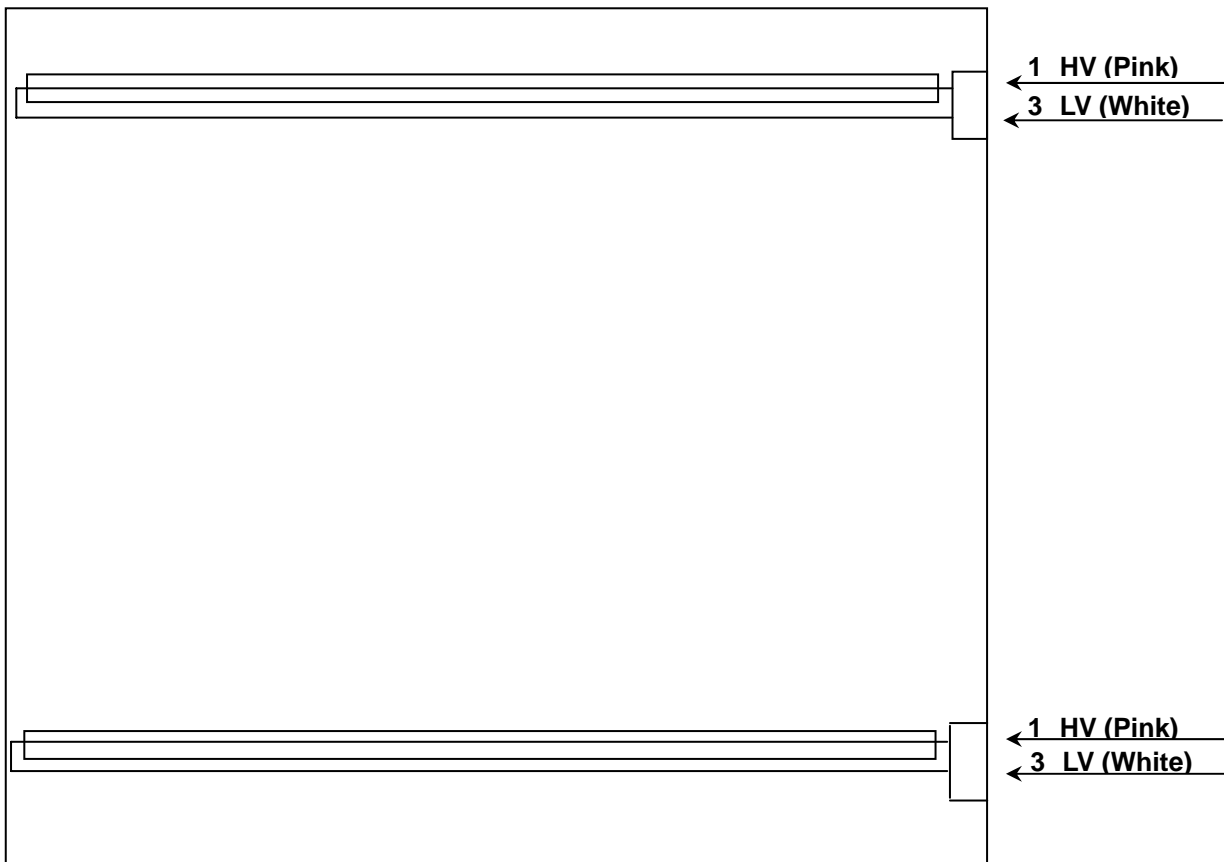

## 5. INPUT TERMINAL PIN ASSIGNMENT

### 5.1 TFT LCD MODULE

Pin No.	Symbol	Function	Polarity	Note
1	VDD	Power Supply +3.3V(typical)		
2	VDD	Power Supply +3.3V(typical)		
3	GND	Ground		
4	GND	Ground		
5	RX0-	LVDS Differential Data Input	Negative	
6	RX0+	LVDS Differential Data Input	Positive	
7	GND	Ground		
8	RX1-	LVDS Differential Data Input	Negative	
9	RX1+	LVDS Differential Data Input	Positive	
10	GND	Ground		
11	RX2-	LVDS Differential Data Input	Negative	
12	RX2+	LVDS Differential Data Input	Positive	
13	GND	Ground		
14	RXCLK-	LVDS Differential Data Input	Negative	
15	RXCLK+	LVDS Differential Data Input	Positive	
16	GND	Ground		
17	RX3-	LVDS Differential Data Input	Negative	
18	RX3+	LVDS Differential Data Input	Positive	
19	GND	Ground		
20	NC	tied to ground		

(1)Connector Part No.: [Hirose] DF14H-20P-1.25H

(2)Matching socket Part No.: [Hirose] DF14-20S-1.25C

### 5.2 BACKLIGHT UNIT

Pin	Symbol	Description	Color
1	HV	High Voltage	Pink/ Blue
3	LV	Ground	White/ Black

Note (1) Connector Part No.: BHR-03VS-1 (JST) or equivalent

Note (2) Matching Connector Part No.: TBD or equivalent

**5.3 COLOR DATA INPUT ASSIGNMENT**

The brightness of each primary color (red, green and blue) is based on the 8-bit gray scale data input for the color. The higher the binary input the brighter the color. The table below provides the assignment of color versus data input.

Color		Data Signal																							
		Red								Green								Blue							
		R7	R6	R5	R4	R3	R2	R1	R0	R7	R6	G5	G4	G3	G2	G1	G0	R7	R6	B5	B4	B3	B2	B1	B0
Basic Colors	Black	0	0	0	0	0	0	0	0	0	0	0	0	0	0	0	0	0	0	0	0	0	0	0	
	Red	1	1	1	1	1	1	1	1	0	0	0	0	0	0	0	0	0	0	0	0	0	0	0	
	Green	0	0	0	0	0	0	0	0	1	1	1	1	1	1	1	1	0	0	0	0	0	0	0	
	Blue	0	0	0	0	0	0	0	0	0	0	0	0	0	0	0	0	1	1	1	1	1	1	1	
	Cyan	0	0	0	0	0	0	0	0	1	1	1	1	1	1	1	1	1	1	1	1	1	1	1	
	Magenta	1	1	1	1	1	1	1	1	0	0	0	0	0	0	0	0	1	1	1	1	1	1	1	
	Yellow	1	1	1	1	1	1	1	1	1	1	1	1	1	1	1	1	0	0	0	0	0	0	0	
	White	1	1	1	1	1	1	1	1	1	1	1	1	1	1	1	1	1	1	1	1	1	1	1	
Gray Scale Of Red	Red(0) / Dark	0	0	0	0	0	0	0	0	0	0	0	0	0	0	0	0	0	0	0	0	0	0		
	Red(1)	0	0	0	0	0	0	0	1	0	0	0	0	0	0	0	0	0	0	0	0	0	0		
	Red(2)	0	0	0	0	0	0	1	0	0	0	0	0	0	0	0	0	0	0	0	0	0	0		
	⋮	⋮	⋮	⋮	⋮	⋮	⋮	⋮	⋮	⋮	⋮	⋮	⋮	⋮	⋮	⋮	⋮	⋮	⋮	⋮	⋮	⋮	⋮		
	⋮	⋮	⋮	⋮	⋮	⋮	⋮	⋮	⋮	⋮	⋮	⋮	⋮	⋮	⋮	⋮	⋮	⋮	⋮	⋮	⋮	⋮	⋮		
	Red(252)	1	1	1	1	1	1	0	1	0	0	0	0	0	0	0	0	0	0	0	0	0	0		
	Red(252)	1	1	1	1	1	1	1	0	0	0	0	0	0	0	0	0	0	0	0	0	0	0		
	Red(252)	1	1	1	1	1	1	1	1	0	0	0	0	0	0	0	0	0	0	0	0	0	0		
Gray Scale Of Green	Green(0)/Dark	0	0	0	0	0	0	0	0	0	0	0	0	0	0	0	0	0	0	0	0	0	0		
	Green(1)	0	0	0	0	0	0	0	0	0	0	0	0	0	0	0	1	0	0	0	0	0	0		
	Green(2)	0	0	0	0	0	0	0	0	0	0	0	0	0	1	0	0	0	0	0	0	0	0		
	⋮	⋮	⋮	⋮	⋮	⋮	⋮	⋮	⋮	⋮	⋮	⋮	⋮	⋮	⋮	⋮	⋮	⋮	⋮	⋮	⋮	⋮			
	⋮	⋮	⋮	⋮	⋮	⋮	⋮	⋮	⋮	⋮	⋮	⋮	⋮	⋮	⋮	⋮	⋮	⋮	⋮	⋮	⋮	⋮	⋮		
	Green(252)	0	0	0	0	0	0	0	0	1	1	1	1	1	1	0	1	0	0	0	0	0	0		
	Green(252)	0	0	0	0	0	0	0	0	1	1	1	1	1	1	1	0	0	0	0	0	0	0		
	Green(252)	0	0	0	0	0	0	0	0	1	1	1	1	1	1	1	1	0	0	0	0	0	0		
Gray Scale Of Blue	Blue(0) / Dark	0	0	0	0	0	0	0	0	0	0	0	0	0	0	0	0	0	0	0	0	0	0		
	Blue(1)	0	0	0	0	0	0	0	0	0	0	0	0	0	0	0	0	0	0	0	0	0	1		
	Blue(2)	0	0	0	0	0	0	0	0	0	0	0	0	0	0	0	0	0	0	0	0	0	1		
	⋮	⋮	⋮	⋮	⋮	⋮	⋮	⋮	⋮	⋮	⋮	⋮	⋮	⋮	⋮	⋮	⋮	⋮	⋮	⋮	⋮	⋮			
	⋮	⋮	⋮	⋮	⋮	⋮	⋮	⋮	⋮	⋮	⋮	⋮	⋮	⋮	⋮	⋮	⋮	⋮	⋮	⋮	⋮	⋮			
	Blue(252)	0	0	0	0	0	0	0	0	0	0	0	0	0	0	0	1	1	1	1	1	1	0		
	Blue(252)	0	0	0	0	0	0	0	0	0	0	0	0	0	0	0	1	1	1	1	1	1	0		
	Blue(252)	0	0	0	0	0	0	0	0	0	0	0	0	0	0	0	1	1	1	1	1	1	1		

Note (1) 0: Low Level Voltage, 1: High Level Voltage

6. INTERFACE TIMING

6.1 INPUT SIGNAL TIMING SPECIFICATIONS

The input signal timing specifications are shown as the following table and timing diagram.

Signal	Item	Symbol	Min.	Typ.	Max.	Unit	Note
DCLK	Pixel Clock	$1/T_C$	-	65	80	MHz	-
DE	Vertical Total Time	$T_V$	780	806	1200	$T_H$	-
	Vertical Address Time	$T_{VD}$	768	768	768	$T_H$	-
	Horizontal Total Time	$T_H$	1140	1344	1600	$T_C$	-
	Horizontal Address Time	$T_{HD}$	1024	1024	1024	$T_C$	-

Note (1) Because this module is operated by DE only mode, Hsync and Vsync input signals should be set to low logic level or ground. Otherwise, this module would operate abnormally.

**INPUT SIGNAL TIMING DIAGRAM**

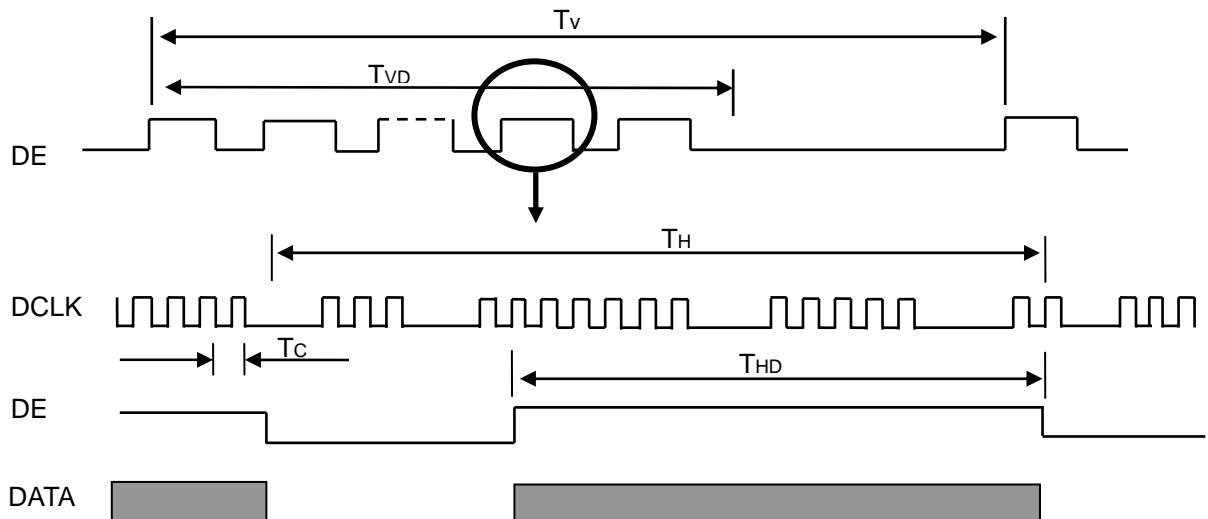

**TIMING DIAGRAM of LVDS**

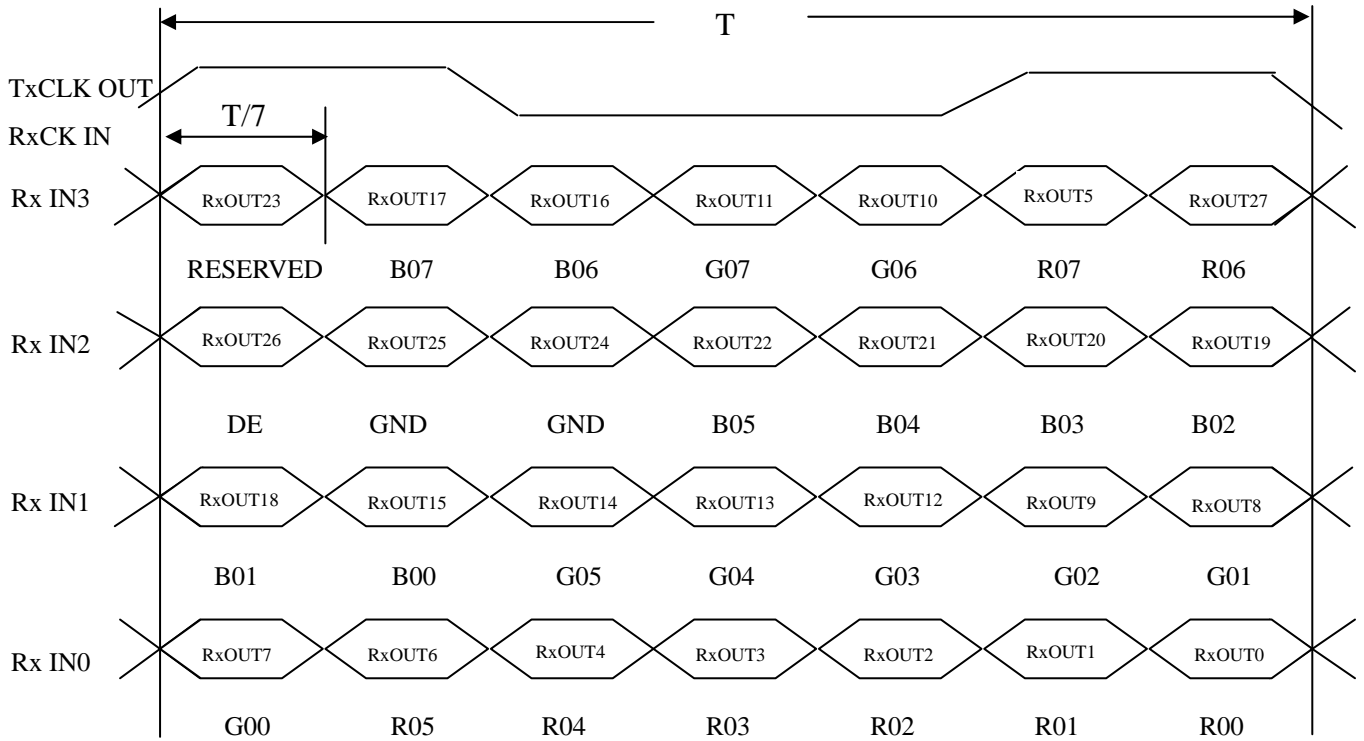



6.2 POWER ON/OFF SEQUENCE

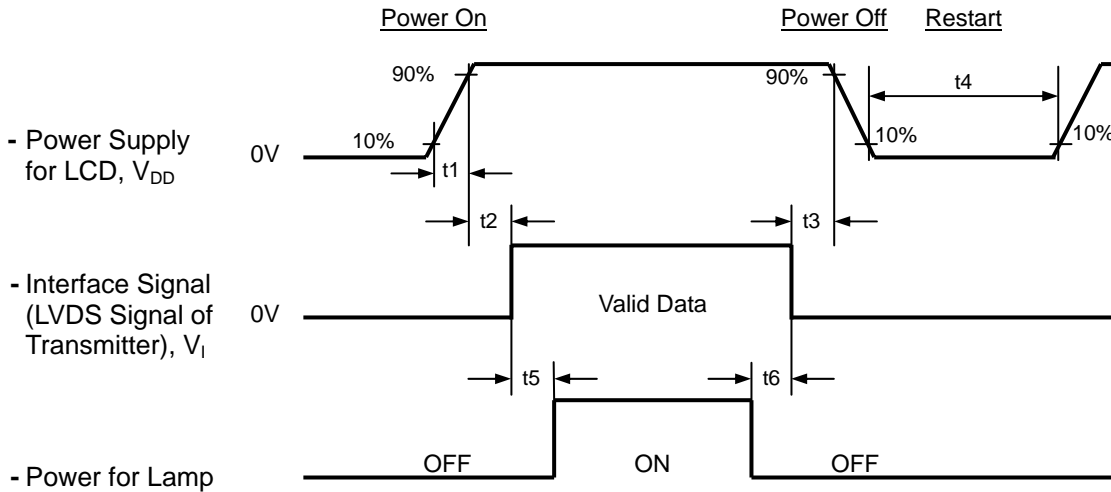

Timing Specifications:

$0.5 < t_1$	10 msec
$0 < t_2$	50 msec
$0 < t_3$	50 msec
$t_4$	500 msec
$t_5$	200 msec
$t_6$	200 msec

Note (1) Please avoid floating state of interface signal at invalid period.

Note (2) When the interface signal is invalid, be sure to pull down the power supply of LCD  $V_{DD}$  to 0 V.

Note (3) The Backlight inverter power must be turned on after the power supply for the logic and the interface signal is valid. The Backlight inverter power must be turned off before the power supply for the logic and the interface signal is invalid.

## 7. OPTICAL CHARACTERISTICS

### 7.1 TEST CONDITIONS

Item	Symbol	Value	Unit
Ambient Temperature	Ta	25±2	°C
Ambient Humidity	Ha	50±10	%RH
Supply Voltage	V <sub>DD</sub>	3.3	V
Input Signal	According to typical value in "3. ELECTRICAL CHARACTERISTICS"		
Inverter Current	I <sub>L</sub>	8.0	mA
Inverter Operating Frequency	F <sub>L</sub>	51	KHz
Inverter	SUMIDA H05 5052		

The measurement methods of optical characteristics are shown in Section 7.2. The following items should be measured under the test conditions described in Section 7.1 and stable environment shown in Note (4).

### 7.2 OPTICAL SPECIFICATIONS

The relative measurement methods of optical characteristics are shown in 7.2. The following items should be measured under the test conditions described in 7.1 and stable environment shown in Note (6).

Item	Symbol	Condition	Min.	Typ.	Max.	Unit	Note	
Color Chromaticity	Red	$\theta_x=0^\circ, \theta_y=0^\circ$ CS-1000T	Typ - 0.03	0.613	Typ+ 0.03	-	(1), (6)	
				0.344				
	Green			Gx				0.302
				Gy				0.567
	Blue			Bx				0.144
				By				0.102
	White			Wx				0.313
				Wy				0.329
Center Luminance of White	L <sub>C</sub>		400	450		cd/m <sup>2</sup>	(4), (6)	
Contrast Ratio	CR		480	700		-	(2), (6)	
Response Time	T <sub>R</sub>	$\theta_x=0^\circ, \theta_y=0^\circ$	-	8	13	ms	(3)	
	T <sub>F</sub>			17	22			
White Variation	δW	$\theta_x=0^\circ, \theta_y=0^\circ$	-	1.25	1.4	-	(6), (7)	
Cross Talk	CT	USB2000	---	---	5.0	%	(5), (6)	
Viewing Angle	Horizontal	CR 10 USB2000	70	80	-	Deg.	(1),(6), (8)	
				θ <sub>x-</sub>	80			-
	Vertical			θ <sub>y+</sub>	80			-
				θ <sub>y-</sub>	80			-

Note (1) Definition of Viewing Angle ( $\theta_x, \theta_y$ ):

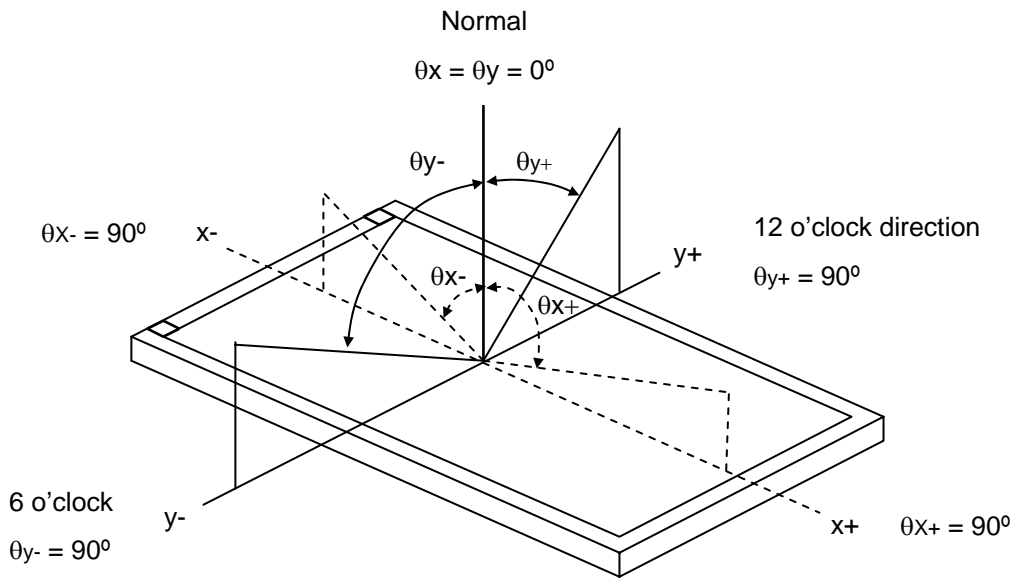

Note (2) Definition of Contrast Ratio (CR):

The contrast ratio can be calculated by the following expression.

$$\text{Contrast Ratio (CR)} = L_{255} / L_0$$

L255: Luminance of gray level 255

L 0: Luminance of gray level 0

$$CR = CR (1)$$

CR (X) is corresponding to the Contrast Ratio of the point X at Figure in Note (5).

Note (3) Definition of Response Time ( $T_R, T_F$ ):

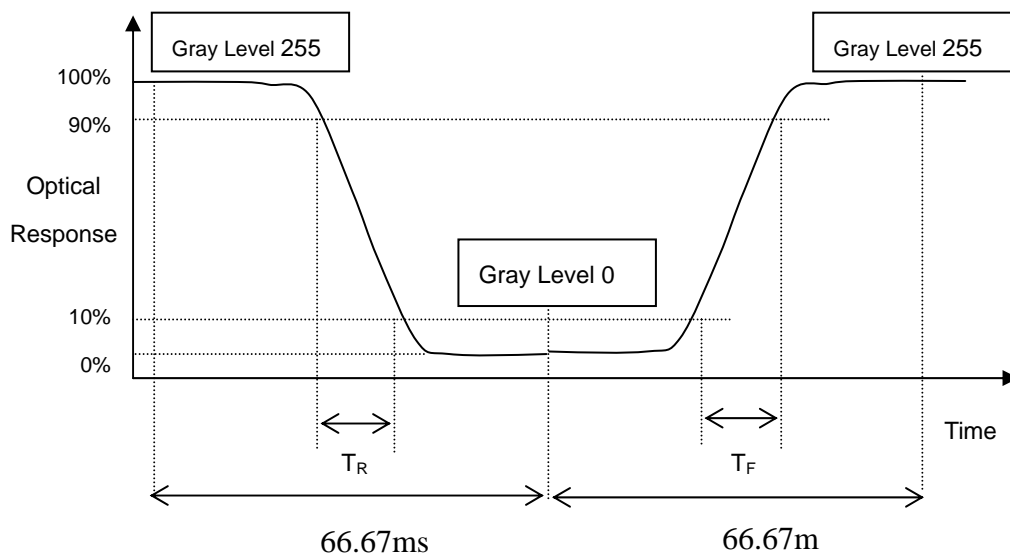

Note (4) Definition of Luminance of White ( $L_C$ ):

Measure the luminance of gray level 255 at center point

$$L_C = L(5)$$

$L(x)$  is corresponding to the luminance of the point  $X$  at Figure in Note (7).

Note (5) Definition of Cross Talk (CT):

$$CT = |Y_B - Y_A| / Y_A \times 100 (\%)$$

Where:

$Y_A$  = Luminance of measured location without gray level 0 pattern ( $cd/m^2$ )

$Y_B$  = Luminance of measured location with gray level 0 pattern ( $cd/m^2$ )

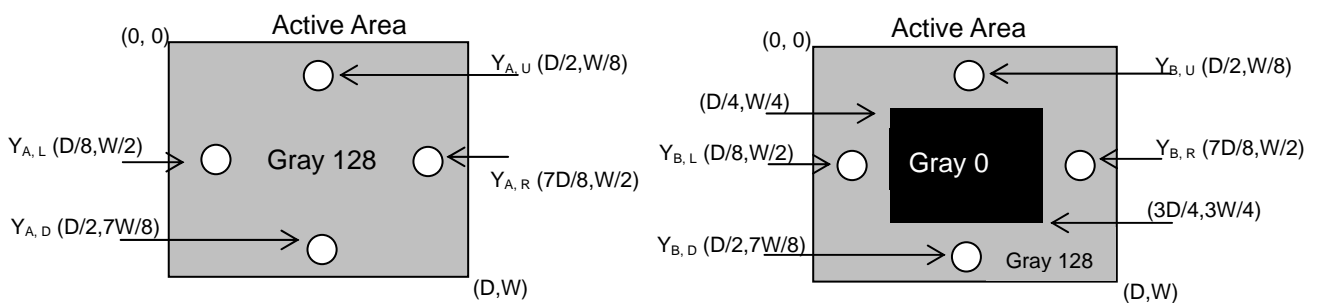

Note (6) Measurement Setup:

The LCD module should be stabilized at given temperature for 20 minutes to avoid abrupt temperature change during measuring. In order to stabilize the luminance, the measurement should be executed after lighting Backlight for 20 minutes in a windless room.

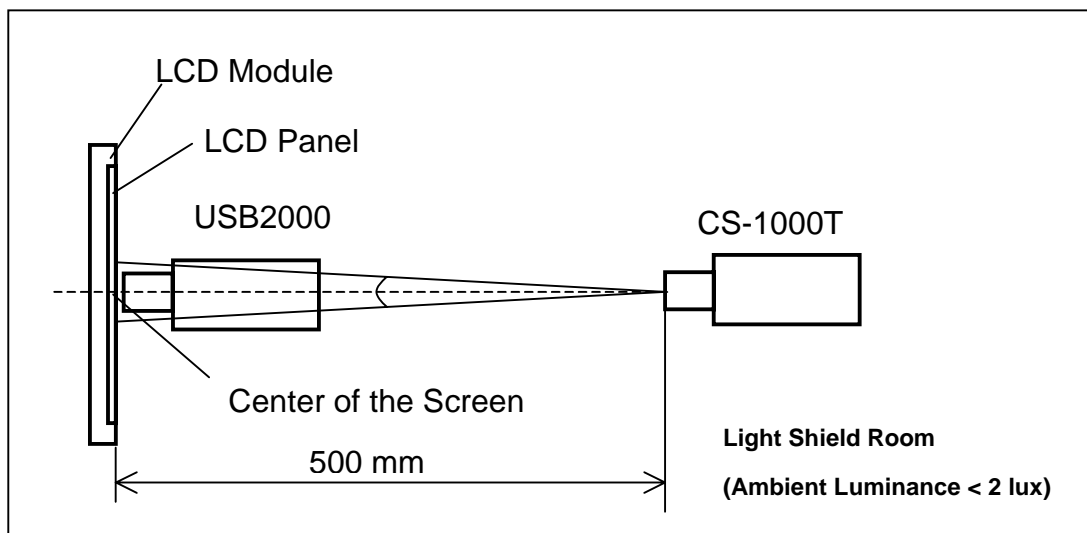

Note (7) Definition of luminance measured points:

Measure the luminance of gray level 255 at point L(1)

Definition of White Variation ( $\delta W$ ):

Measure the luminance of gray level 255 at 9 points

$$\delta W = \frac{\text{Maximum [L (1), L (6), L (7), L (8), L (9), L (10), L (11), L (12), L (13)]}}{\text{Minimum [L (1), L (6), L (7), L (8), L (9), L (10), L (11), L (12), L (13)]}}$$

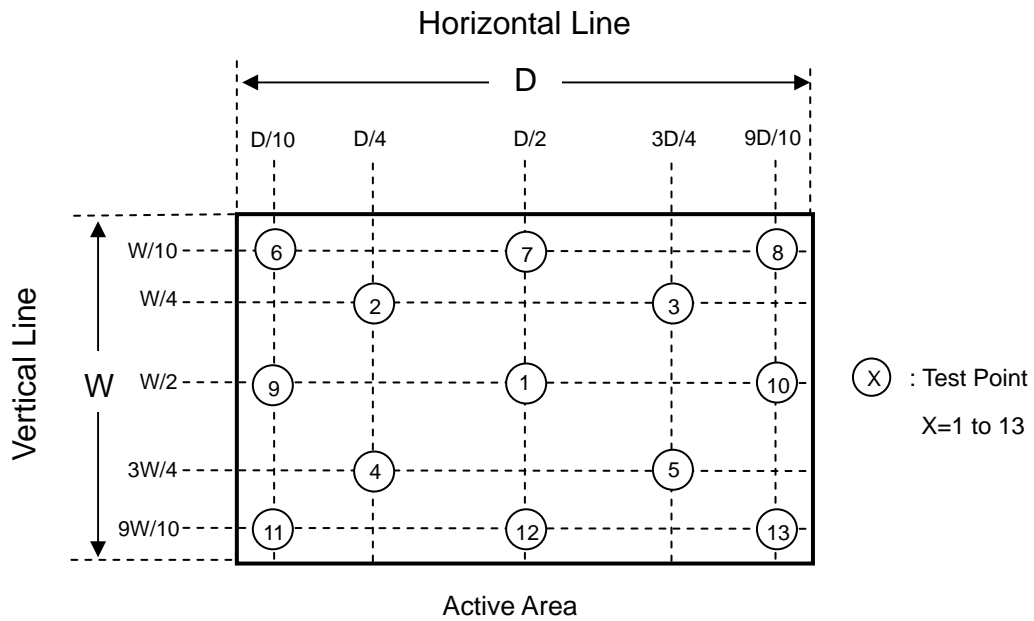

Note (8) TN type has Gray scale inversion occurs at  $\theta_y = 40^\circ$

8. RELIABILITY TEST CRITERIA

Test Item	Test Condition	Note
High Temperature Storage Test	80°C, 240 hours	(1), (2)
Low Temperature Storage Test	-40°C, 240 hours	
Thermal Shock Storage Test	-40°C, 0.5hour 80 , 0.5hour; 100cycles, 1hour/cycle	
High Temperature Operation Test	70°C, 240 hours	
Low Temperature Operation Test	-30°C, 240 hours	
High Temperature & High Humidity Operation Test	60°C, RH 90%, 240hours	
Heat Cycle Operation Test	-30°C, 1hour 70°C, 1hour; 50cycles, 4hour/cycle	
ESD Test (Operation)	150pF, 330 , 1sec/cycle Condition 1 : panel contact, ±8KV Condition 2 : panel non-contact ±15KV	(2)
Shock (Non-Operating)	50G, 11ms, half sine wave, 1 time for ± X, ± Y, ± Z direction	(2), (3)
Vibration (Non-Operating)	1.5G, 10 ~ 500 Hz sine wave, 1.5mm Max, 30min/cycle, 1 cycles each X, Y, Z direction	(2), (3)

Note (1) No condensation of water.

Note (2) No display malfunction.

Note (3) At testing Vibration and Shock, the fixture in holding the module has to be hard and rigid enough so that the module would not be twisted or bent by the fixture.

Note (4) Temperature of panel display surface area should be 80 °C Max.

## 9. PRECAUTIONS

### 9.1 HANDLING PRECAUTIONS

- (1) The module should be assembled into the system firmly by using every mounting hole. Be careful not to twist or bend the module.
- (2) While assembling or installing modules, it can only be in the clean area. The dust and oil may cause electrical short or damage the polarizer.
- (3) Use fingerstalls or soft gloves in order to keep display clean during the incoming inspection and assembly process.
- (4) Do not press or scratch the surface harder than a HB pencil lead on the panel because the polarizer is very soft and easily scratched.
- (5) If the surface of the polarizer is dirty, please clean it by some absorbent cotton or soft cloth. Do not use Ketone type materials (ex. Acetone), Ethyl alcohol, Toluene, Ethyl acid or Methyl chloride. It might permanently damage the polarizer due to chemical reaction.
- (6) Wipe off water droplets or oil immediately. Staining and discoloration may occur if they left on panel for a long time.
- (7) If the liquid crystal material leaks from the panel, it should be kept away from the eyes or mouth. In case of contacting with hands, legs or clothes, it must be washed away thoroughly with soap.
- (8) Protect the module from static electricity, it may cause damage to the C-MOS Gate Array IC.
- (9) Do not disassemble the module.
- (10) Do not pull or fold the lamp wire.
- (11) Pins of I/F connector should not be touched directly with bare hands.
- (12) Do not keep same pattern in a long period of time. It may cause image sticking on LCD.

### 9.2 STORAGE PRECAUTIONS

- (1) High temperature or humidity may reduce the performance of module. Please store LCD module within the specified storage conditions.
- (2) It is dangerous that moisture come into or contacted the LCD module, because the moisture may damage LCD module when it is operating.
- (3) It may reduce the display quality if the ambient temperature is lower than 10 °C. For example, the response time will become slowly, and the starting voltage of lamp will be higher than the room temperature.

### 9.3 OPERATION PRECAUTIONS

- (1) Do not pull the I/F connector in or out while the module is operating.
- (2) Always follow the correct power on/off sequence when LCD module is connecting and operating. This can prevent the CMOS LSI chips from damage during latch-up.

The startup voltage of Backlight is approximately 1000 Volts. It may cause electrical shock while assembling with inverter. Do not disassemble the module or insert anything into the Backlight unit.



10. PACKAGING

10.1 PACKING SPECIFICATIONS

- (1) 10 LCD modules / 1 Box
- (2) Box dimensions : 511(L) X 420(W) X 360(H) mm
- (3) Weight : approximately 12.7Kg ( 10 modules per box)

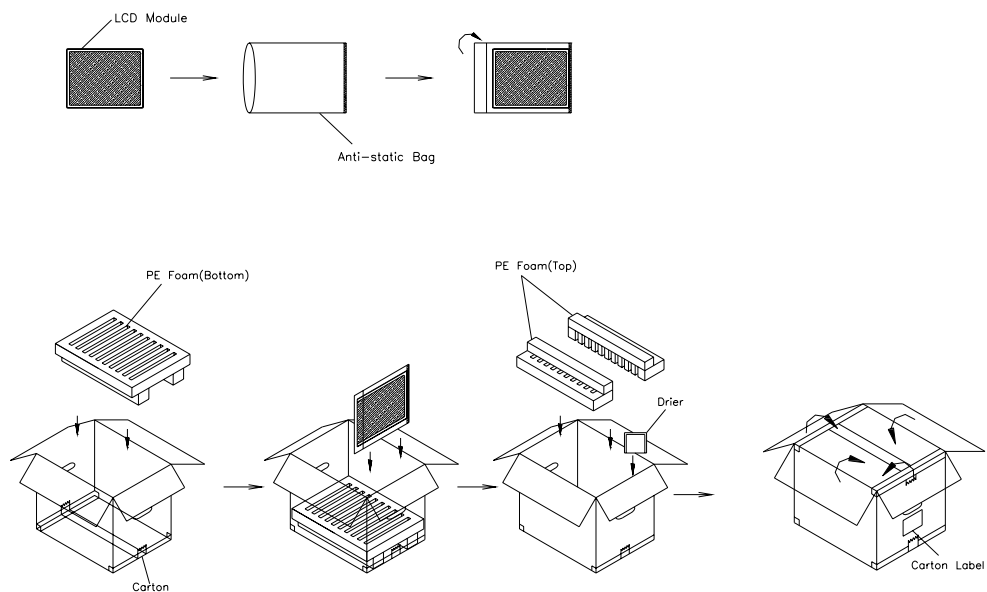

- (1) 10 modules/1 box
- (2) Carton dimensions : 511(L)x420(W)x360(H)mm
- (3) Weight : approximately 12.7kg(10 modules per box).

Figure 10-1

10.2 PACKING Method

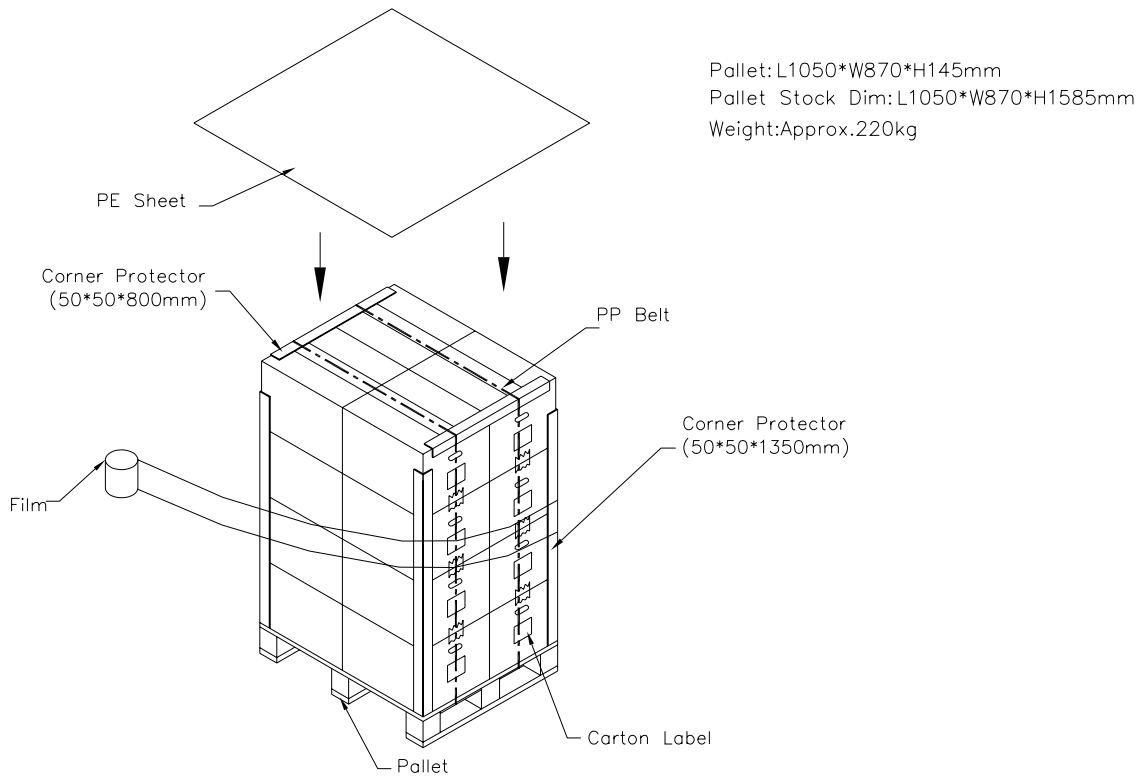
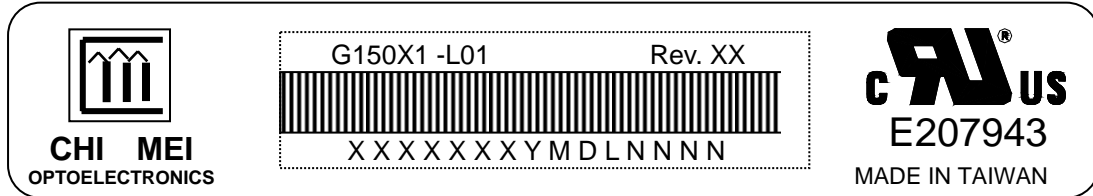

Figure 10-2

11. DEFINITION OF LABELS

11.1 CMO MODULE LABEL

The barcode nameplate is pasted on each module as illustration, and its definitions are as following explanation.



- (a) Model Name: G150X1 –L01
- (b) Revision: Rev. XX, for example: C1, C2 ...etc.
- (c) Serial ID: XXXXXXYMDLNNNN

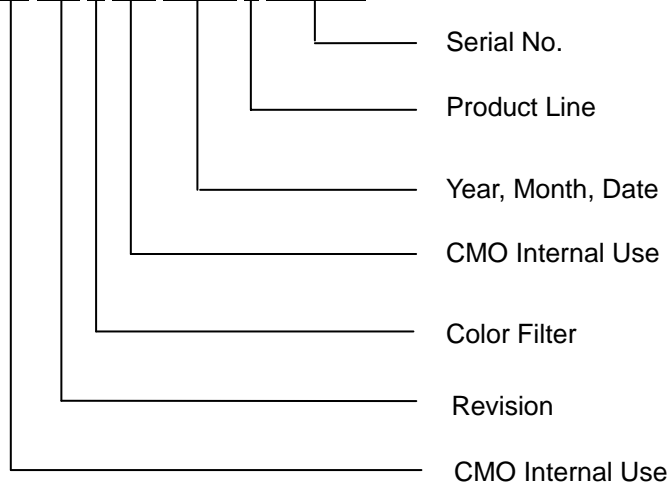

Serial ID includes the information as below:

- (a) Manufactured Date: Year: 1~9, for 2000~2009  
 Month: 1~9, A~C, for Jan. ~ Dec.  
 Day: 1~9, A~Y, for 1<sup>st</sup> to 31<sup>st</sup>, exclude I and O
- (b) Revision Code: cover all the change
- (c) Color Filter: 0 ->CMO, 2 -> Toppan
- (d) Serial No.: Manufacturing sequence of product
- (e) Product Line: 1 -> Line1, 2 -> Line 2, ...etc.

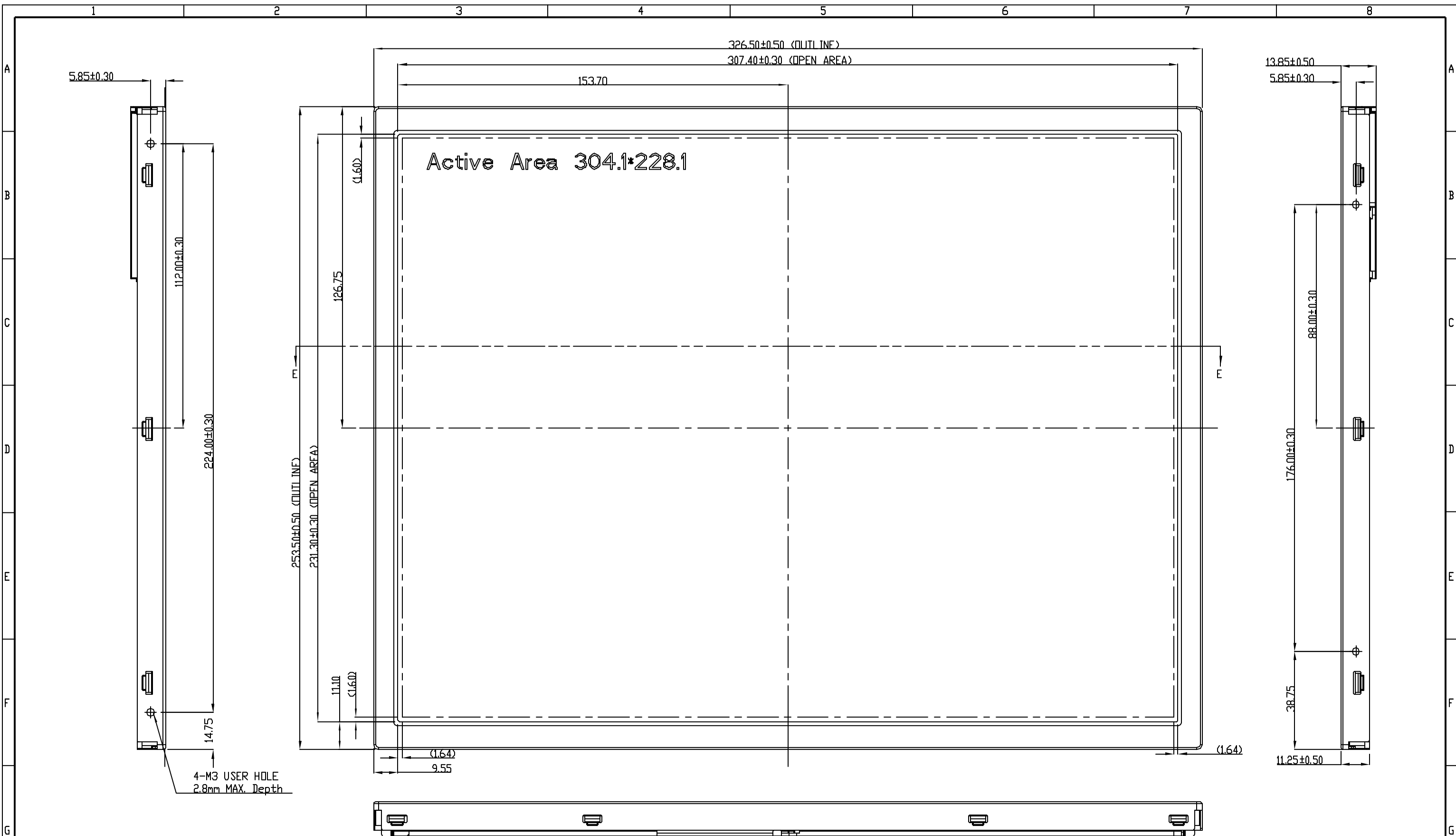

NOTE:  
 1. OUTLINE TOLERANCE: ±0.5mm.  
 2. I/F CONNECTOR: DF14H-20P-1.25H (Hirose)  
 3. LAMP CONNECTOR: BHR-03VS-1 (JST)  
 4. SIDE MOUNT HOLE ROTATIONAL TORQUE MUST BE MAX. 5kgf-cm.

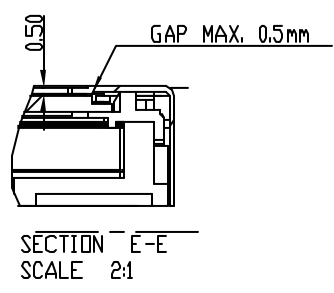

Mark	Description	Date	Changed_By	Approved_By	ECN No.	Remark

TITLE	ASSY_MODULE_G150X1			2D REV.   A
				3D REV.   2
Approved	JEMMY_CHANG	Drawing No.	G15014101A	
Checked	ROCKY YANG	Part No.	MFOX50190L	
Drawer	JS_JIANG	Material	TBD	Sheet 1 / 2 AP
Designer	JS_JIANG	Date	22-May-2006	Scale 1:1 Unit mm
		CHI MEI OPTOELECTRONICS CORP.		
ALL RIGHTS RESERVED, COPYING FORBIDDEN				

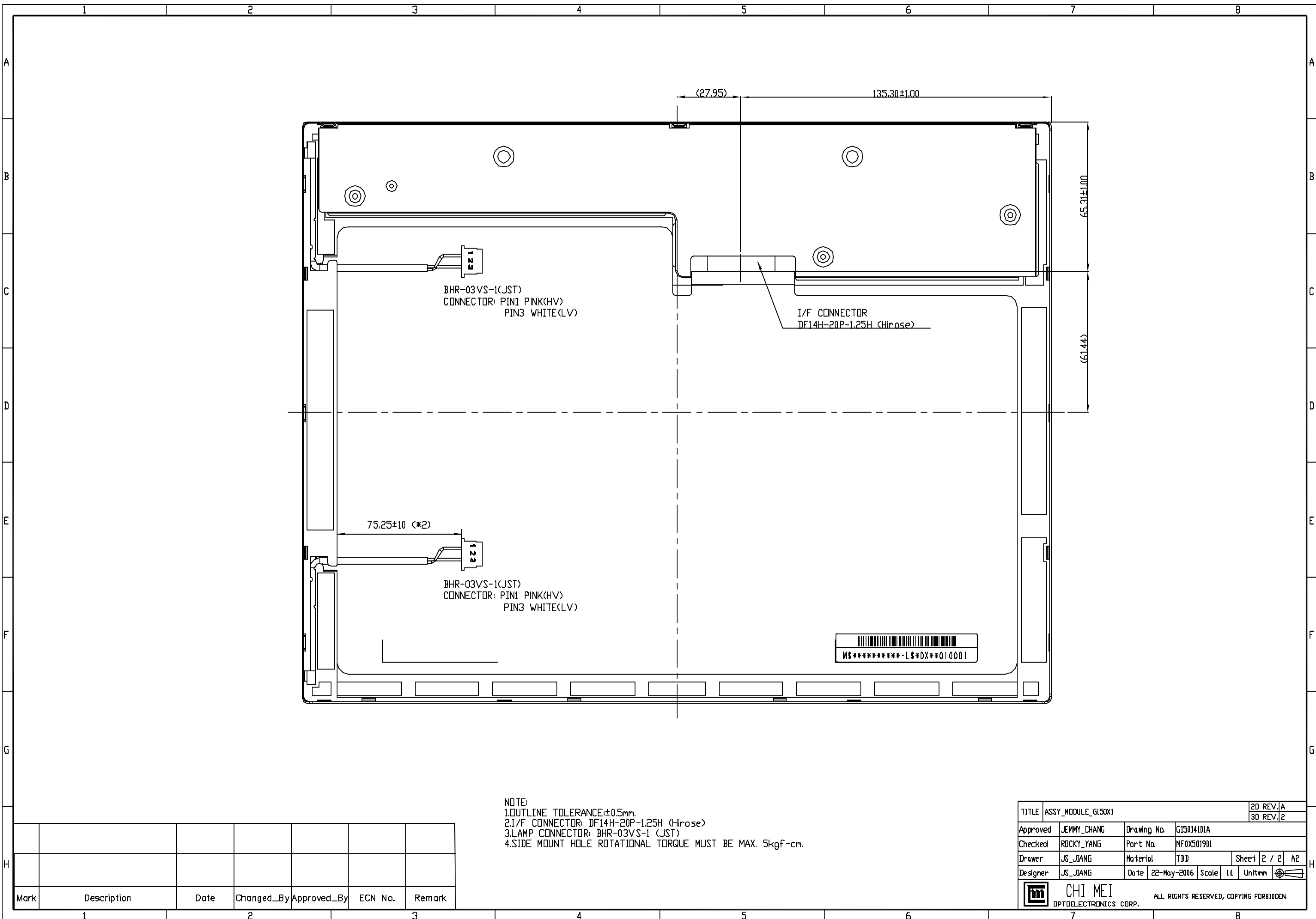

Mark	Description	Date	Changed_By	Approved_By	ECN No.	Remark

TITLE	ASSY_MODULE_G150X1			2D REV.   A
				3D REV.   2
Approved	JEMMY_CHANG	Drawing No.	G15014101A	
Checked	ROCKY YANG	Part No.	MFOX50190L	
Drawer	JS_JIANG	Material	TBD	Sheet 2 / 2 AP
Designer	JS_JIANG	Date	22-May-2006	Scale 1:1 Unit mm
		<b>CHI MEI</b> OPTOELECTRONICS CORP. ALL RIGHTS RESERVED, COPYING FORBIDDEN		



DATA DISPLAY GROUP

Our company network supports you worldwide with offices in Germany, Turkey, Great Britain and the USA. For more information please contact:



DISTEC GmbH

**Distec GmbH**

Augsburger Str. 2b  
82110 Germering  
Germany

Phone: +49 (0)89 / 89 43 63-0  
Fax: +49 (0)89 / 89 43 63-131  
E-Mail: info@distec.de  
Internet: www.distec.de



DATA DISPLAY TEKNOLOJI

**Data Display Teknoloji Elektronik San Ve Diş Tic A.Ş.**

Kustepe Leylak Sok.  
Nursanlar Is Merkezi  
Kat. 6 No: 21  
Sisli / Istanbul  
Turkey

Phone: +90 (0)212 / 356 04 20  
Fax: +90 (0)212 / 356 04 25  
E-Mail: info@datadisplay.com.tr  
Internet: www.datadisplay.com.tr



DISPLAY TECHNOLOGY

**Display Technology Ltd.**

A2 Spectrum Business Centre  
Anthonys Way, Medway City Estate  
Rochester, Kent, ME2 4NP  
United Kingdom

Phone: + 44 (0)1634 / 29 55 55  
Fax: + 44 (0)1634 / 29 55 43  
E-Mail: info@displaytechnology.co.uk  
Internet: www.displaytechnology.co.uk



**Apollo  
Display  
Technologies**

A Data Display Company

**Apollo Display Technologies, Corp.**

85 Remington Blvd.  
Ronkonkoma, NY 11779  
United States of America

Phone: +1 631 / 580-43 60  
Fax: +1 631 / 580-43 70  
E-Mail: info@apollodisplays.com  
Internet: www.apollodisplays.com